

HEP HEPT

HEP: Wall-mounted axial fans, with IP65 motor
HEPT: Long-cased axial fans, with IP65 motor

Wall-mounted axial (HEP) and long-cased (HEPT) fans, with fibreglass-reinforced plastic impeller.



HEP



HEPT

Fan:

- Airflow direction from motor to impeller
- Impeller in polyamide 6 reinforced with fibre glass
- HEP: Sheet steel base plate.
- HEP: Protection guard to prevent contacts according to standard UNE-EN ISO 12499:2010
- HEPT: Sheet steel cased casing
- HEPT: Outside connecting box, IP-65 protection

Motor:

- Class F motors, with ball bearings, IP65 protection
- Single-phase 220-240V -50Hz. and three-phase 220-240/380-415V -50Hz.
- Fan working temperature: -25°C +60°C, 4-6-8 pole motors and -25°C +45°C, 2 pole motors

resin polymerised at 190°C, after alkaline degreasing with phosphate-free nanotechnology treatment.

On request:

- Motor, impeller and guard unit (version F)
- Motor-impeller unit (version G)
- Airflow direction from impeller to motor
- Special windings for different voltages

Finish:

- Anticorrosive finish in polyester

Order code



HEP: Wall-mounted axial fans, with IP65 motor
 HEPT: Long-cased axial fans, with IP65 motor

Impeller diameter in cm.

Number of motor poles
 4=1400 r/min. 50 Hz
 6=900 r/min. 50 Hz
 8=750 r/min. 50 Hz

T=Three-phase
 M=Single-phase
 H=High airflow
 L=Low airflow

Air circulation
 I=Impeller
 Motor->Impeller

 A=Airflow-in
 Impeller->Motor

Execution of the fan
 Execution standard

F=Motor impeller unit guard

G=Motor impeller unit

Technical characteristics

Model	Speed (r/min)	Maximum admissible current (A)		Installed power at free airflow (W)	Maximum airflow (m3/h)	Sound pressure level dB(A)	Approx. weight (Kg)	
		220-240V	380-415V				HEP	HEPT
HEP-25-2T/H	2780	1.30	0.75	265	2300	64	5.3	-
HEP-25-2M/H	2750	1.95	-	345	2300	64	5.3	-
HEP-25-4T/H	1450	0.69	0.40	85	1250	52	4.5	-
HEP-25-4M/H	1440	0.65	-	95	1250	52	4.5	-
HEP-31-2T/H	HEPT-31-2T/H	2640	1.54	0.89	400	74	7.0	7.4
HEP-31-2M/H	HEPT-31-2M/H	2640	2.30	-	410	74	7.0	7.4
HEP-31-4T/H	HEPT-31-4T/H	1410	0.69	0.40	115	55	5.7	6.2
HEP-31-4M/H	HEPT-31-4M/H	1410	0.75	-	130	55	5.7	6.2
HEP-31-4T/L	-	1430	0.69	0.40	100	54	5.1	-
HEP-31-4M/L	-	1420	0.70	-	110	54	5.1	-
HEP-35-2T/H	HEPT-35-2T/H	2790	2.16	1.25	550	76	8.8	9.4
HEP-35-2M/H	HEPT-35-2M/H	2675	2.80	-	560	76	8.8	9.4
HEP-35-4T/H	HEPT-35-4T/H	1340	0.74	0.43	155	58	7.1	7.6
HEP-35-4M/H	HEPT-35-4M/H	1340	0.98	-	160	58	7.1	7.6
HEP-35-4T/L	-	1410	0.69	0.40	110	56	6.5	-
HEP-35-4M/L	-	1410	0.75	-	120	56	6.5	-
HEP-40-4T/H	HEPT-40-4T/H	1420	2.10	1.20	245	61	10.6	13.5
HEP-40-4M/H	HEPT-40-4M/H	1400	1.85	-	355	61	10.6	13.5

Technical characteristics

Model	Speed (r/min)	Maximum admissible current (A)		Installed power at free airflow (W)	Maximum airflow (m ³ /h)	Sound pressure level dB(A)	Approx. weight (Kg)		
		220-240V	380-415V				HEP	HEPT	
HEP-40-4T/L	-	1450	2.10	1.20	185	4000	60	10.6	-
HEP-40-4M/L	-	1420	1.55	-	260	4000	60	10.6	-
HEP-40-6T/H	HEPT-40-6T/H	960	1.12	0.65	155	3500	54	10.2	13.5
HEP-40-6M/H	HEPT-40-6M/H	960	1.06	-	185	3500	54	10.2	13.5
HEP-45-4T/H	HEPT-45-4T/H	1400	2.11	1.22	475	7300	66	12.5	15.5
HEP-45-4M/H	HEPT-45-4M/H	1400	2.35	-	490	7300	66	12.5	15.5
HEP-45-4T/L	-	1440	2.10	1.20	300	5810	64	11.0	-
HEP-45-4M/L	-	1360	1.85	-	315	5810	64	11.0	-
HEP-45-6T/H	HEPT-45-6T/H	955	1.42	0.82	215	4900	56	11.4	15.5
HEP-45-6M/H	HEPT-45-6M/H	955	1.40	-	225	4900	56	11.4	15.5
HEP-50-4T/H	HEPT-50-4T/H	1420	3.10	1.80	740	10150	69	15.0	18.0
HEP-50-4M/H	HEPT-50-4M/H	1380	3.35	-	710	10150	69	15.0	18.0
HEP-50-4T/L	-	1400	2.15	1.25	390	7300	67	13.0	-
HEP-50-4M/L	-	1370	2.30	-	430	7300	67	13.0	-
HEP-50-6T/H	HEPT-50-6T/H	950	1.38	0.80	205	6150	59	13.2	18.0
HEP-50-6M/H	HEPT-50-6M/H	950	1.38	-	215	6150	59	13.2	18.0
HEP-56-4T/H	HEPT-56-4T/H	1350	3.63	2.10	870	12800	72	21.0	28.0
HEP-56-4M/H	HEPT-56-4M/H	1350	5.26	-	895	12800	72	21.0	28.0
HEP-56-4T/L	-	1400	3.20	1.85	710	10900	70	19.0	-
HEP-56-4M/L	-	1350	3.40	-	755	10900	70	19.0	-
HEP-56-6T/H	HEPT-56-6T/H	915	1.73	1.00	325	8250	62	17.0	28.0
HEP-56-6M/H	HEPT-56-6M/H	915	2.12	-	450	8250	62	17.0	28.0
HEP-63-4T/H	HEPT-63-4T/H	1415	6.92	4.00	1400	18700	82	25.8	33.5
HEP-63-4T/L	-	1375	5.01	2.90	1275	16500	75	23.0	-
HEP-63-4M/L	-	1375	5.40	-	1160	16500	75	23.0	-
HEP-63-6T/H	HEPT-63-6T/H	905	2.06	1.19	405	12050	65	20.2	33.5
HEP-63-6M/H	HEPT-63-6M/H	905	2.70	-	540	12050	65	20.2	33.5
HEP-63-6T/L	-	945	1.62	0.94	305	9450	63	19.4	-
HEP-63-6M/L	-	945	1.80	-	330	9450	63	19.4	-
HEP-63-8T/H	-	700	1.90	1.10	320	8250	57	19.2	-
HEP-63-8M/H	-	700	1.89	-	320	8250	57	19.2	-



Erp. BEP (best efficiency point) characteristics

MC	Measurement category	ηe[%]	Efficiency
EC	Efficiency category	N	Degree of efficiency
S	Static	[kW]	Electrical power
T	Total	[m³/h]	Airflow
VSD	Variable-speed drive	[mmH₂O]	Static or total pressure (According to EC)
SR	Specific relationship	[RPM]	Speed

Model	MC	EC	VSD	SR	ηe [%]	N	[kW]	[m ³ /h]	[mmH ₂ O]	[RPM]
25-4T/H	-	-	-	-	-	-	0.083	986	2.73	1471
25-4M/H	-	-	-	-	-	-	0.096	990	2.72	1466
31-2T/H	A	S	NO	1.00	30.3%	39.2	0.397	2782	15.89	2827
31-2M/H	A	S	NO	1.00	28.9%	37.6	0.417	2793	15.84	2854
31-4T/H	-	-	-	-	-	-	0.109	1304	5.05	1449
31-4M/H	-	-	-	-	-	-	0.122	1290	5.10	1461
31-4T/L	-	-	-	-	-	-	0.096	1141	4.37	1460
31-4M/L	-	-	-	-	-	-	0.109	1161	4.30	1452
35-2T/H	A	S	NO	1.00	35.3%	42.9	0.620	4356	18.46	2880
35-2M/H	A	S	NO	1.00	34.6%	42.2	0.632	4396	18.28	2851
35-4T/H	A	S	NO	1.00	28.3%	39.9	0.145	2167	6.95	1418
35-4M/H	A	S	NO	1.00	26.1%	37.4	0.158	2191	6.89	1430
35-4T/L	-	-	-	-	-	-	0.117	1874	4.95	1443
35-4M/L	-	-	-	-	-	-	0.124	1919	4.97	1451
40-4T/H	A	S	NO	1.00	26.8%	37.5	0.202	2135	9.28	1470
40-4T/L	A	S	NO	1.00	26.3%	37.5	0.172	2248	7.41	1476
45-4T/H	A	S	NO	1.00	33.1%	41.8	0.418	4235	11.98	1447
45-4M/H	A	S	NO	1.00	29.3%	37.6	0.480	4541	11.37	1450
45-4T/L	A	S	NO	1.00	33.0%	42.7	0.292	3719	9.53	1467
45-4M/L	A	S	NO	1.00	30.9%	40.4	0.314	3805	9.36	1439
50-4T/H	A	S	NO	1.00	31.1%	38.7	0.626	5994	11.92	1458



Erp. BEP (best efficiency point) characteristics

Model	MC	EC	VSD	SR	η_e [%]	N	[kW]	[m3/h]	[mmH ₂ O]	[RPM]
50-4M/H	A	S	NO	1.00	30.1%	37.6	0.645	5967	11.96	1446
50-4T/L	A	S	NO	1.00	32.9%	41.8	0.387	4894	9.54	1446
50-4M/L	A	S	NO	1.00	29.0%	37.6	0.438	4853	9.61	1434
50-6T/H	A	S	NO	1.00	28.6%	39.5	0.187	3484	5.64	977
50-6M/H	A	S	NO	1.00	26.8%	37.5	0.201	3601	5.50	979
56-4T/H	A	S	NO	1.00	31.3%	38.3	0.798	7546	12.16	1432
56-4M/H	A	S	NO	1.00	30.8%	37.7	0.817	7780	11.88	1442
56-4T/L	A	S	NO	1.00	30.3%	37.7	0.697	7344	10.57	1448
56-4M/L	A	S	NO	1.00	29.0%	36.2	0.730	7358	10.55	1432
56-6T/H	A	S	NO	1.00	27.7%	37.5	0.283	4469	6.46	964
63-4T/H	A	S	NO	1.00	32.0%	37.7	1.253	10152	14.52	1462
63-4T/L	A	S	NO	1.00	36.0%	41.9	1.170	10263	15.10	1432
63-4M/L	A	S	NO	1.00	34.8%	40.8	1.138	10512	13.85	1445
63-6T/H	A	S	NO	1.00	28.5%	37.6	0.373	6577	5.95	957
63-6T/L	A	S	NO	1.00	29.7%	39.3	0.300	5326	6.13	973
63-6M/L	A	S	NO	1.00	28.4%	37.9	0.314	5389	6.07	969

Acoustic features

The specified values are determined according to free field measurements of pressure and sound levels in dB(A) at an equivalent distance of twice the fan's span plus the impeller's diameter, with a minimum of 1.5 m.

Sound power Lw(A) spectrum in dB(A) via frequency band in Hz.

Model	63	125	250	500	1000	2000	4000	8000	Model	63	125	250	500	1000	2000	4000	8000
25-2/H	39	52	64	68	70	70	66	58	45-6/H	33	47	59	62	64	65	61	52
25-4/H	27	40	52	56	58	58	54	46	50-4/H	46	60	72	75	77	78	74	65
31-2/H	49	62	74	78	80	80	76	68	50-4/L	44	58	70	73	75	76	72	63
31-4/H	30	43	55	59	61	61	57	49	50-6/H	36	50	62	65	67	68	64	55
31-4/L	29	42	54	58	60	60	56	48	56-4/H	49	63	75	78	80	81	77	68
35-2/H	51	64	76	80	82	82	78	70	56-4/L	47	61	73	76	78	79	75	66
35-4/H	33	46	58	62	64	64	60	52	56-6/H	39	53	65	68	70	71	67	58
35-4/L	31	44	56	60	62	62	58	50	63-4/H	61	75	87	90	92	92	89	80
40-4/H	36	49	61	65	67	67	63	55	63-4/L	54	68	80	83	85	85	82	73
40-4/L	35	48	60	64	66	66	62	54	63-6/H	44	58	70	73	75	75	72	63
40-6/H	29	42	54	58	60	60	56	48	63-6/L	42	56	68	71	73	73	70	61
45-4/H	43	57	69	72	74	75	71	62	63-8/H	36	50	62	65	67	67	64	55
45-4/L	41	55	67	70	72	73	69	60									

Dimensions in mm

HEP

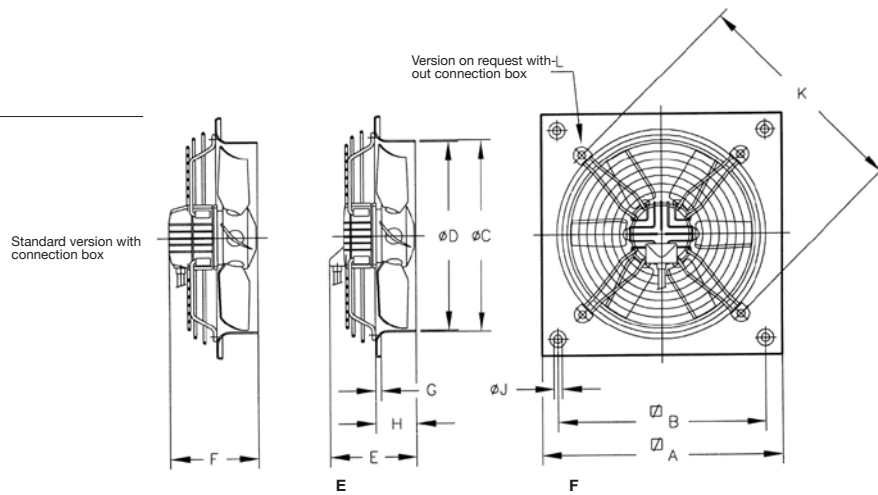

Model	∅A	∅B	∅C	∅D	2T	4T	6T	8T	2T	4T	6T	8T	G	H	∅J	K	L
HEP-25	330	275	262	260	189	179	-	-	213	203	-	-	11	56	8.5	310	M.8
HEP-31.../H	400	336	310.5	308	190	180	-	-	214	204	-	-	11	75	10.5	380	M.8
HEP-31.../L	400	336	310.5	308	-	180	-	-	-	204	-	-	11	75	10.5	380	M.8
HEP-35.../H	465	390	362.5	360	217	187	-	-	241	211	-	-	11	86	10.5	450	M.8
HEP-35.../L	465	390	362.5	360	-	187	-	-	-	211	-	-	11	86	10.5	450	M.8
HEP-40.../H	532	452	412.5	410	-	206	186	-	-	226	205	-	11	97.5	10.5	500	M.8
HEP-40.../L	532	452	412.5	410	-	206	-	-	-	226	-	-	11	97.5	10.5	500	M.8
HEP-45.../H	596	504	462.5	460	-	214	199	-	-	234	218	-	11	105	10.5	560	M.8
HEP-45.../L	596	504	462.5	460	-	214	-	-	-	234	-	-	11	105	10.5	560	M.8
HEP-50.../H	665	562	516.5	514	-	255	235	-	-	275	254	-	11	115	10.5	640	M.8
HEP-50.../L	665	562	516.5	514	-	240	-	-	-	260	-	-	11	115	10.5	640	M.8
HEP-56.../H	710	630	563	560	-	287	247	-	-	306	266	-	15	115	10.5	721	M.8
HEP-56.../L	710	630	563	560	-	267	-	-	-	286	-	-	15	115	10.5	721	M.8
HEP-63.../H	800	710	638	635	-	-	257	247	-	340	276	266	15	140	10.5	820	M.8
HEP-63.../L	800	710	638	635	-	320	247	-	-	340	266	-	15	140	10.5	820	M.8

Dimensions in mm

HEPT

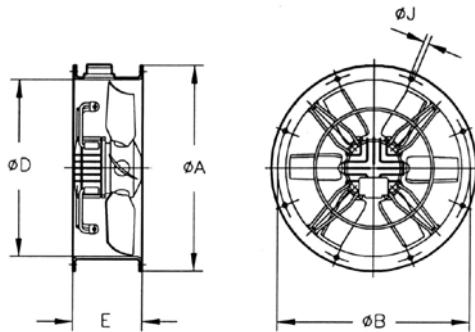

Model	ϕA	ϕB	ϕD	E	ϕJ	Drills No
HEPT-31	385	355	308	200	10	8
HEPT-35	425	395	360	220	10	8
HEPT-40	490	450	410	220	12	8
HEPT-45	540	500	460	220	12	8
HEPT-50	600	560	514	230	12	12
HEPT-56	660	620	560	260	12	12
HEPT-63	730	690	635	350	12	12

Characteristic curves

Q = Airflow in m³/h, m³/s and cfm.

Pe = Static pressure in mmH₂O, Pa and inwg.

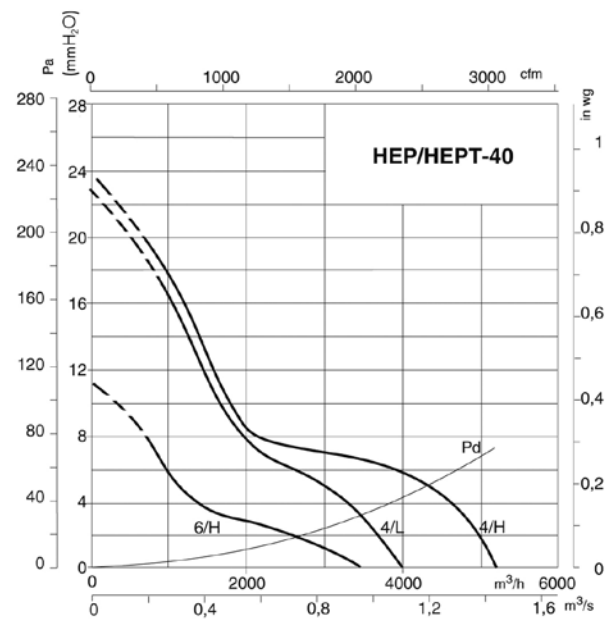
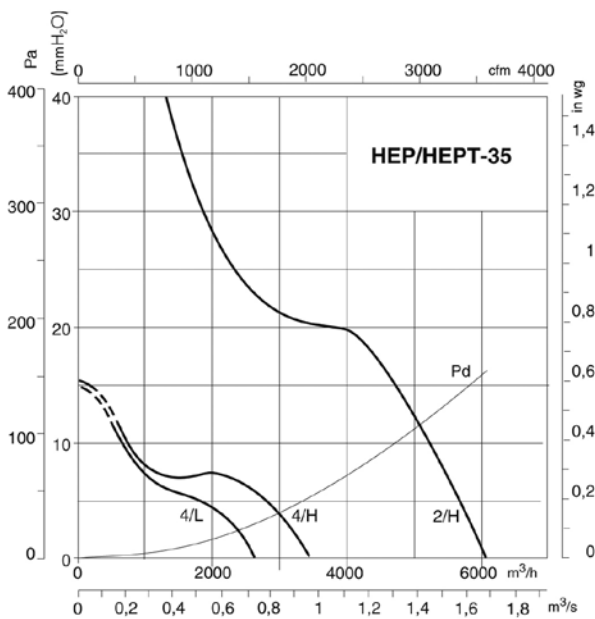
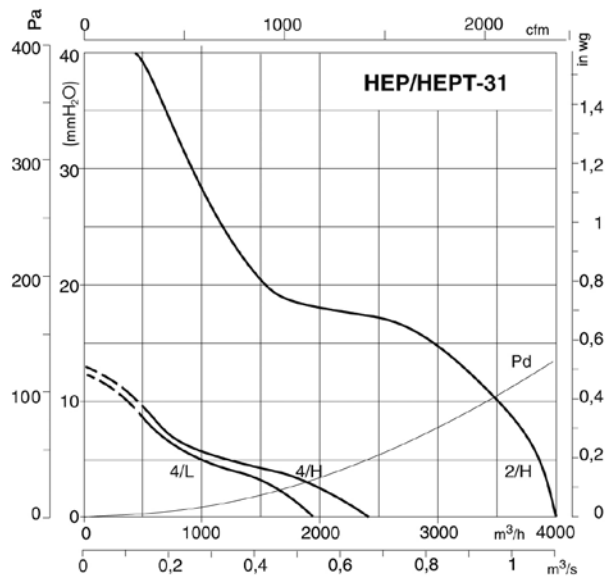
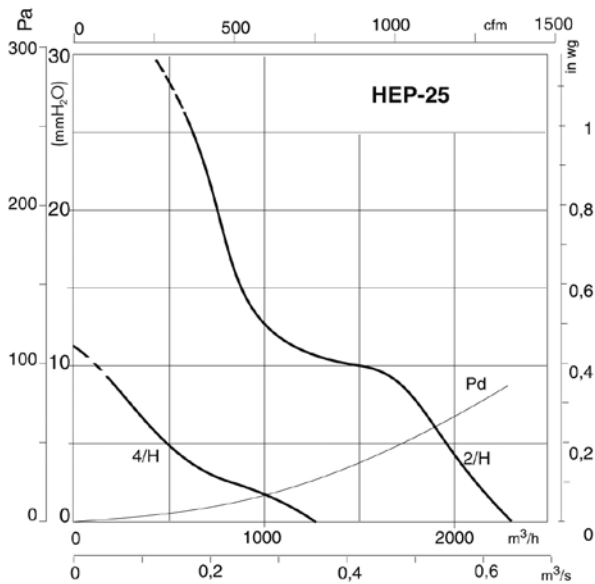

Characteristic curves

Q = Airflow in m³/h, m³/s and cfm.

Pe = Static pressure in mmH₂O, Pa and inwg.

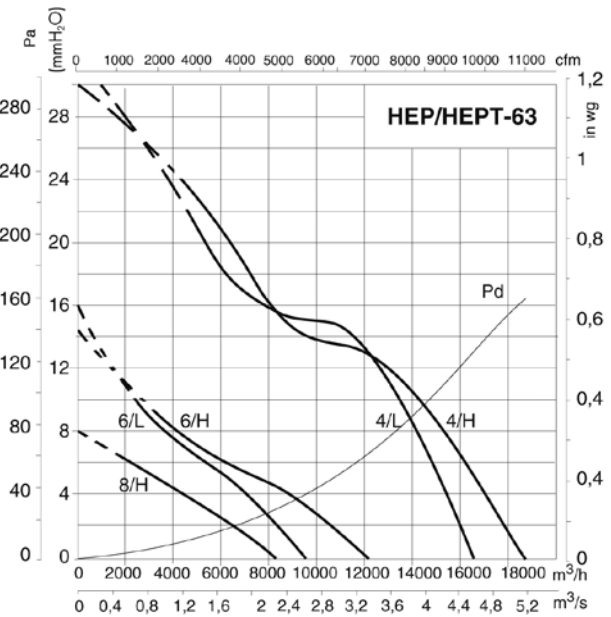
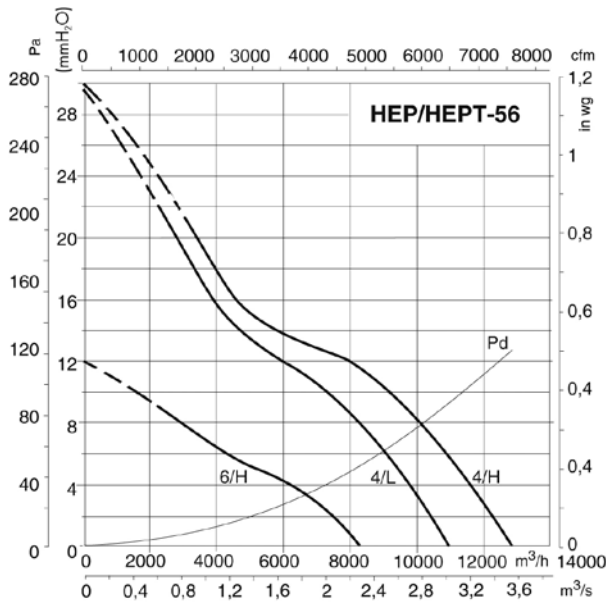
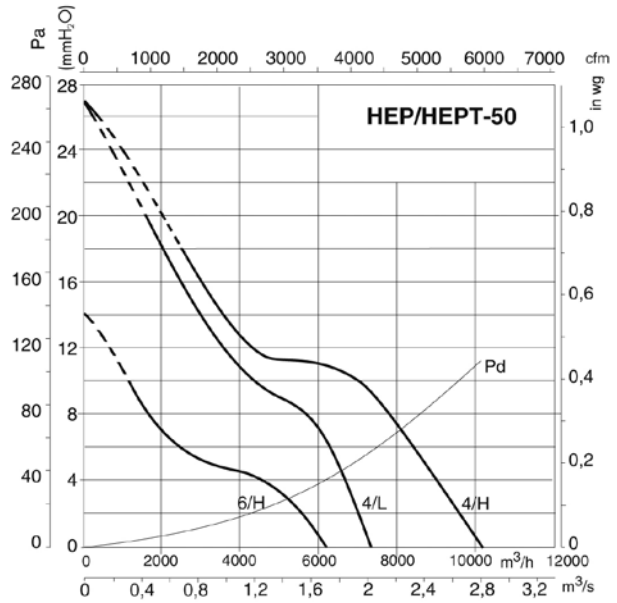
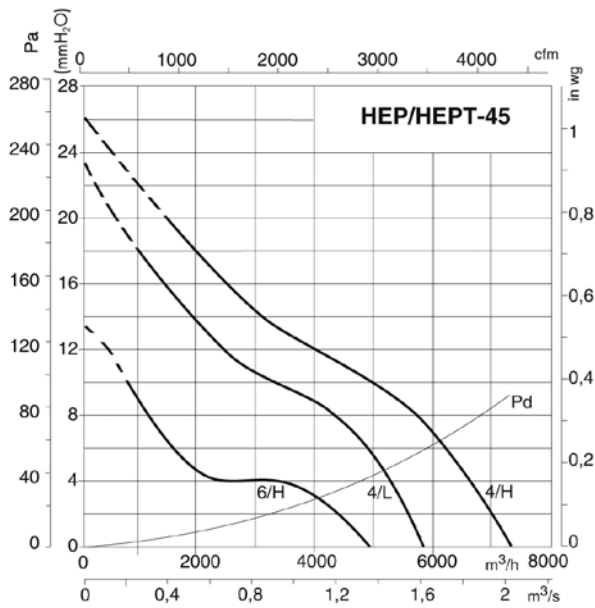

Accessories

See accessories section.

