

CHT/ATEX CVT/ATEX

Centrifugal roof fans with horizontal or vertical air outlet with ATEX certification and possible Ex e, Ex d, Ex tc and Ex tb marked

Ex "e" marked: C[Ⓒ]Ex II 2G Ex e
Ex "d" marked: C[Ⓒ]Ex II 2G Ex d
Ex tc marked: C[Ⓒ]Ex II 3D Ex tc
Ex tb marked: C[Ⓒ]Ex II 2D Ex tb
Notified authority: L.O.M
Identification No: LOM3ATEX147



CHT



CVT

CHT: Centrifugal roof fans with horizontal air outlet and hood in aluminium, ATEX certification CEE ExII2G Ex e explosion-proof and CEE ExII2G Ex d, Ex tc or Ex tb flame-resistant to work in explosive atmospheres of gas or dust.
 CVT: Centrifugal roof fans with vertical air outlet and hood in aluminium, ATEX certification CEE ExII2G Ex e explosion-proof and CEE ExII2G Ex d, Ex tc or Ex tb flame-resistant to work in explosive atmospheres of gas or dust.

Fan:

- ATEX base support with copper inlets made of brass according to standard EN-14986:2007.
- Impeller with backward-curved blades
- Bird guard
- Aluminium rain deflector hood

Motor:

- Class F motors with ball bearings and ATEX certification, Ex e explosion-proof and Ex d, Ex tc, or Ex tb flame-resistant
- Three phase, 50Hz, 230/400V motors up to and including 4kW. 400/690V over 4kW
- Max. air temperature to transport: -20°C+ 80°C

Finish:

- Anticorrosive galvanised sheet steel and aluminium

On request:

- Built-in motors with PTC
- Special windings for different electrical supplies and frequencies
- ATEX construction for different categories
- Fans with two-speed motor.
- Ex d flame-resistant single-phase motors

Order code



CHT: Centrifugal roof fans with horizontal air outlet, ATEX certified.

Impeller size

CVT: Centrifugal roof fans with vertical air outlet, ATEX certified.

Number of motor pole

4=1400 r/min. 50 Hz
6=900 r/min. 50 Hz

T=Three-phase

Ex-e: marked: C[Ⓒ]Ex II 2G Ex e IIB T3
 Ex "d" marked: C[Ⓒ]Ex II 2G Ex d IIB T5
 Ex tc marked: C[Ⓒ]Ex II 3D Ex tc
 Ex tb marked: C[Ⓒ]Ex II 2D Ex tb

Marked:

- C[Ⓒ]Ex II 2G c
- C[Ⓒ]Ex II 2D c
- C[Ⓒ]Ex II 3D c

Technical characteristics

Model	Speed (r/min)	Maximum current admissible (A)		Installed power (kW)	Maximum airflow (m³/h)	Sound level dB(A)		Approx. weight (Kg)
		230V	400V			Inlet	Outlet	
CHT/ATEX CVT/ATEX 200-4T	1370	2.08	1.20	0.25	1450	37	43	25
CHT/ATEX CVT/ATEX 225-4T	1370	2.08	1.20	0.25	2100	41	47	25
CHT/ATEX CVT/ATEX 225-6T	910	2.42	1.40	0.25	1400	30	36	26
CHT/ATEX CVT/ATEX 250-4T	1370	2.08	1.20	0.25	3100	45	50	34
CHT/ATEX CVT/ATEX 250-6T	910	2.42	1.40	0.25	2000	33	40	35
CHT/ATEX CVT/ATEX 315-4T	1410	2.94	1.70	0.55	4950	48	54	39
CHT/ATEX CVT/ATEX 315-6T	935	2.77	1.60	0.37	3200	37	43	39
CHT/ATEX CVT/ATEX 400-4T	1410	3.81	2.20	0.75	7000	55	61	57
CHT/ATEX CVT/ATEX 400-6T	935	2.77	1.60	0.37	4500	44	50	56
CHT/ATEX CVT/ATEX 450-4T	1400	6.93	4.00	1.50	10200	59	64	66
CHT/ATEX CVT/ATEX 450-6T	935	2.77	1.60	0.37	6900	47	54	59
CHT/ATEX CVT/ATEX 500-6T	910	5.89	3.40	1.10	12000	51	57	103
CHT/ATEX CVT/ATEX 560-6T	940	9.35	5.40	2.20	17300	54	61	126
CHT/ATEX CVT/ATEX 630-6T	950	18.88	10.90	4.00	24700	58	64	166

(1) The sound level values are measurements of pressure in dB(A) at a distance of 6 m and at 2/3 of the maximum airflow (2/3 Qmax.)

Acoustic features

The specified values are determined according to free field measurements of pressure and sound levels in dB(A) at a distance of 6 m.

Sound power Lw(A) spectrum in dB(A) via frequency band in Hz.

Values taken at the inlet with 2/3 of the maximum airflow (2/3Qmax).

Model	63	125	250	500	1000	2000	4000	8000
200	35	41	52	55	56	52	50	44
225-4	42	51	56	56	60	59	52	46
225-6	31	40	45	45	49	48	41	35
250-4	46	55	60	60	64	63	56	50
250-6	34	43	48	48	52	51	44	38
315-4	50	56	62	62	65	68	59	53
315-6	39	45	51	51	54	57	48	42
315-8	35	41	47	47	50	53	44	38
400-4	57	63	69	69	72	75	66	60
400-6	46	52	58	58	61	64	55	49
400-8	42	48	54	54	57	60	51	45
450-4	62	69	74	74	78	77	70	65
450-6	50	57	62	62	66	65	58	53
450-8	46	53	58	58	62	61	54	49
450-12	35	42	47	47	51	50	43	38
500-6	54	60	65	66	70	69	62	55
500-8	47	53	58	59	63	62	55	48
500-12	39	45	50	51	55	54	47	40
560-6	57	63	68	69	73	72	65	58
560-8	49	55	60	61	65	64	57	50
560-12	42	48	53	54	58	57	50	43
630-6	61	67	72	73	77	76	69	62
630-8	53	59	64	65	69	68	61	54
630-12	46	52	57	58	62	61	54	47

Values taken at outlet with 2/3 of the maximum airflow (2/3Qmax).

Model	63	125	250	500	1000	2000	4000	8000
200	39	44	58	60	61	61	56	51
225-4	41	50	60	64	67	64	57	51
225-6	30	39	49	53	56	53	46	40
250-4	44	53	63	67	70	67	60	54
250-6	34	43	53	57	60	57	50	44
315-4	49	61	69	71	72	72	64	56
315-6	38	50	58	60	61	61	53	45
315-8	34	46	54	56	57	57	49	41
400-4	56	68	76	78	79	79	71	63
400-6	45	57	65	67	68	68	60	52
400-8	41	53	61	63	64	64	56	48
450-4	60	72	80	82	83	80	73	65
450-6	50	62	70	72	73	70	63	55
450-8	45	57	65	67	68	65	58	50
450-12	35	47	55	57	58	55	48	40
500-6	50	64	72	76	75	72	66	60
500-8	43	57	65	69	68	65	59	53
500-12	35	49	57	61	60	57	51	45
560-6	54	68	76	80	79	76	70	64
560-8	46	60	68	72	71	68	62	56
560-12	39	53	61	65	64	61	55	49
630-6	57	71	79	83	72	79	73	67
630-8	50	64	72	76	72	72	66	60
630-12	42	56	64	68	67	64	58	52

To obtain the Lwa sound power spectra in dB(A) at the inlet with the maximum airflow (Qmax), add the values in the following tables to the LpA sound pressure level given on the characteristic curves:

Frequency band in Hz							
63	125	250	500	1000	2000	4000	8000
2	9	15	15	18	18	11	5

Dimensions in mm

CHT

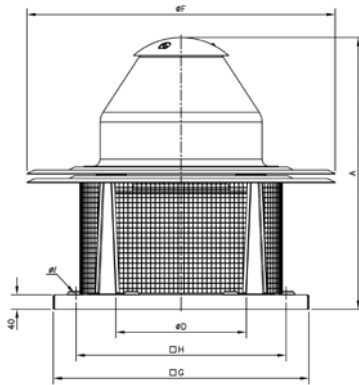

Model	A	øD*	øF	G	H	øl
CHT-200	552	250	570	450	360	12
CHT-225	570	250	570	450	360	12
CHT-250	632	355	726	560	450	12
CHT-315	682	355	726	560	450	12
CHT-400	755	500	856	710	590	12
CHT-450	770	500	856	710	590	12
CHT-500	846	630	1075	900	750	14
CHT-560	1035	710	1300	1100	900	14
CHT-630	1098	710	1300	1100	900	14

(*) Recommended nominal diameter for duct.

CVT

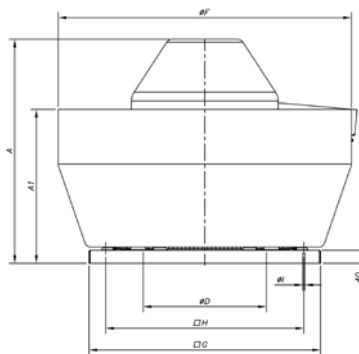

Model	A	A1	øD*	øF	G	H	øl
CVT-200	500	308	250	530	450	360	12
CVT-225	517	308	250	530	450	360	12
CVT-250	580	380	355	705	560	450	12
CVT-315	630	380	355	705	560	450	12
CVT-400	690	475	500	900	710	590	12
CVT-450	705	475	500	900	710	590	12
CVT-500	775	545	630	1100	900	750	14
CVT-560	956	676	710	1295	1100	900	14
CVT-630	1017	676	710	1295	1100	900	14

(*) Recommended nominal diameter for duct.

Characteristic curves

Q = Airflow in m³/h, m³/s and cfm.

Pe = Static pressure in mmH₂O, Pa and inwg.

The Lp (dB(A)) sound levels given on the curves are free field pressure measurements at 6 metres at the inlet.

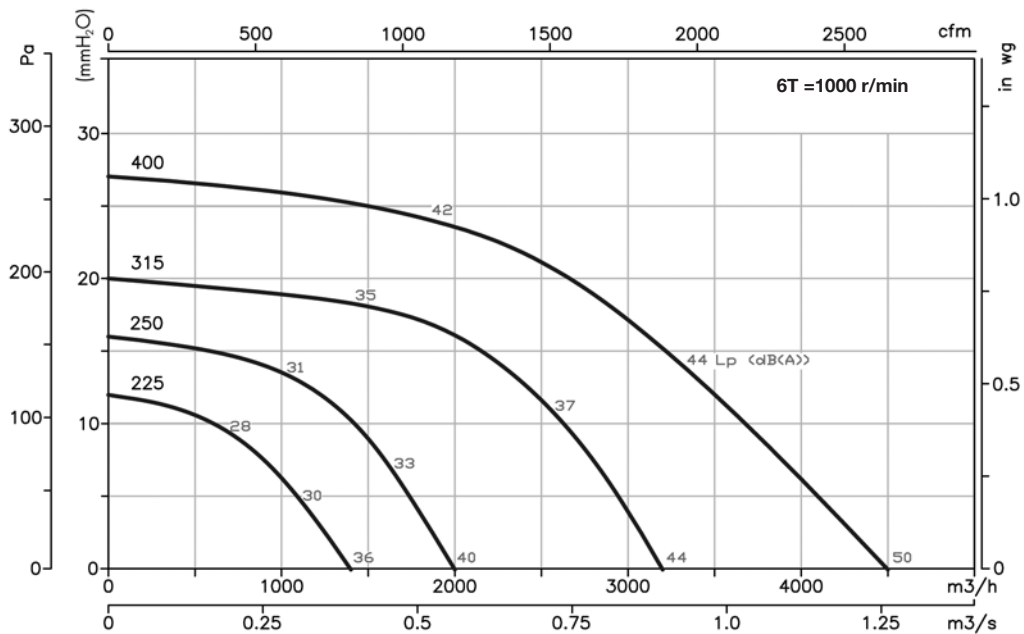
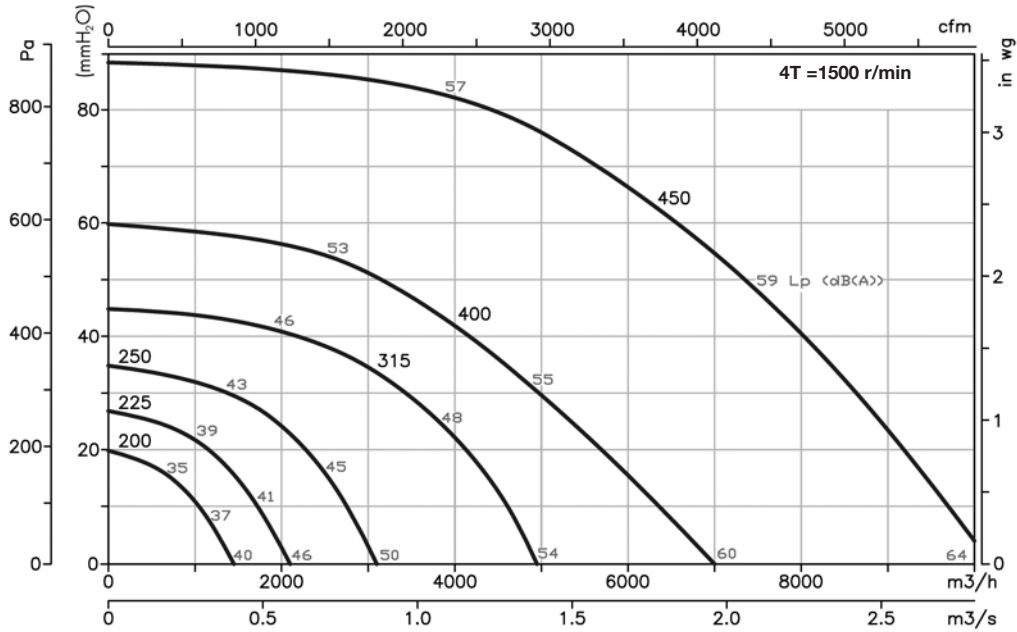

Characteristic curves

Q = Airflow in m³/h, m³/s and cfm.

Pe = Static pressure in mmH₂O, Pa and inwg.

The Lp (dB(A)) sound levels given on the curves are free field pressure measurements at 6 metres at the inlet.

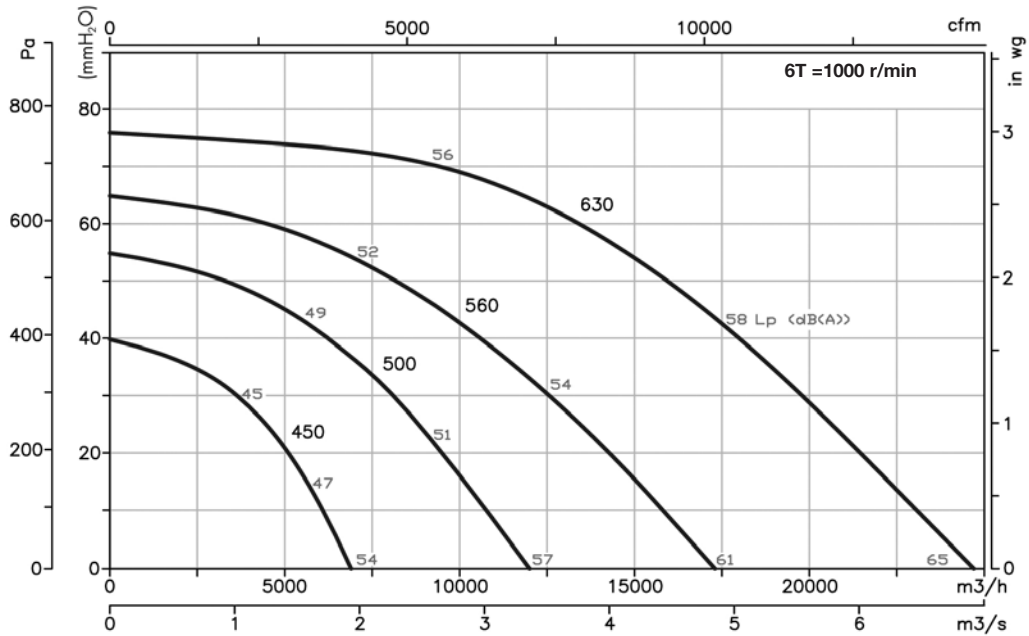

Variation of sound pressure depending on distance

The sound level may vary depending on the roof structure.

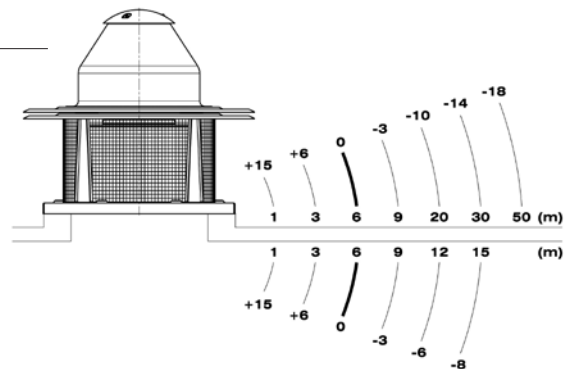

Accessories

See accessories section.

