

CHT CVT

400°C/2h centrifugal roof fans with horizontal or vertical air outlet

CHT: 400°C/2h centrifugal roof fans with horizontal air outlet, hood in aluminium

CVT: 400°C/2h centrifugal roof fans with vertical air outlet, hood in aluminium

Fan:

- Galvanised sheet steel base plate.
- Impeller with backward-curved blades made from galvanised sheet steel
- Bird guard
- Aluminium rain deflector hood
- Approval according to Standard EN12101-3:2002/AC:2006, with certification No. 0370-CPR-0897

Motor:

- IE2 efficiency motors for capacities equal to or over 0.75kW and below 7.5kW, except single-phase, 2 speed and 8 pole motors.
- Class F motors, with ball bearings and IP55 protection, except single-phase versions, IP54 protection, one- or two-speed depending on the model
- Single-phase 230V.-50Hz., and three-phase 230/400V.-50Hz.
- Max. air temperature to transport: -25°C + 120°C

Finish:

- Anticorrosive galvanized sheet steel and aluminium

On request:

- Special windings for different voltages.
- ATEX certification, Category 3.

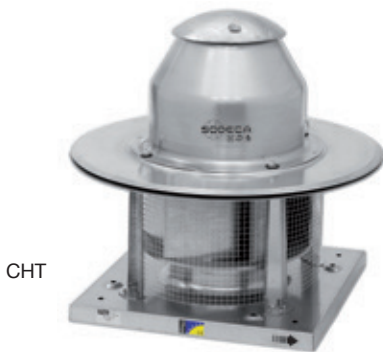

CHT



CVT



Brackets that aid mounting on the roof



Order code

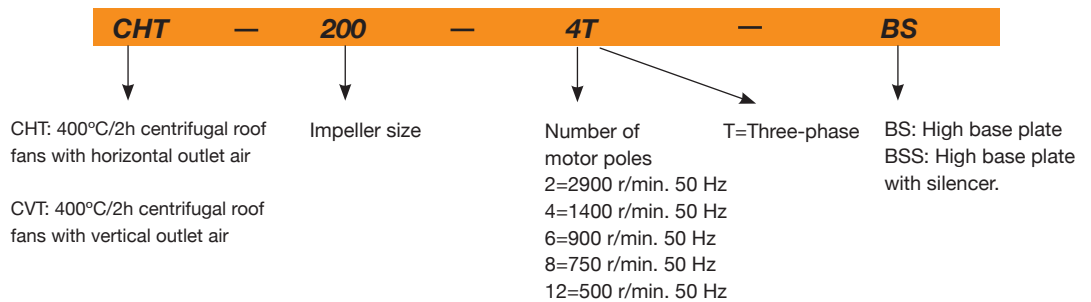

Technical characteristics

Model	Speed (r/min)	Maximum admissible current (A)		Installed capacity (kW)	Maximum airflow (m³/h)	Sound level dB(A)		Approx. weight (Kg)
		230V	400V			Inlet	Outlet	
CHT CVT 200-4T	1350	1.66	0.96	0.25	1450	37	43	25
CHT CVT 200-4M	1380	0.65		0.25	1450	37	43	25
CHT CVT 225-4T	1350	1.66	0.96	0.25	2100	41	47	25
CHT CVT 225-4M	1380	0.95		0.25	2100	41	47	25
CHT CVT 225-6T	900	1.51	0.87	0.25	1400	30	36	26
CHT CVT 225-6M	890	0.50		0.25	1400	30	36	26
CHT CVT 250-4T	1350	1.66	0.96	0.25	3100	45	50	34
CHT CVT 250-4M	1380	1.35		0.25	3100	45	50	34
CHT CVT 250-6T	900	1.51	0.87	0.25	2000	33	40	35
CHT CVT 250-6M	890	0.65		0.25	2000	33	40	35
CHT CVT 315-4T	1380	2.92	1.69	0.55	4950	48	54	39
CHT CVT 315-4/8T	1450/720		1.70 / 0.80	0.55 / 0.19	4950 / 2475	48 / 33	54 / 39	40

Technical characteristics

Model	Speed (r/min)	Maximum admissible current (A)		Installed capacity (kW)	Maximum airflow (m³/h)	Sound level dB(A)		Approx. weight (Kg)
		230V	400V			Inlet	Outlet	
CHT CVT 315-4M	1380	3.30		0.55	4950	48	54	39
CHT CVT 315-6T	900	2.24	1.30	0.37	3200	37	43	39
CHT CVT 315-6M	910	0.95		0.37	3200	37	43	39
CHT CVT 400-4T	1410	3.10	1.79	0.75	7000	55	61	57
CHT CVT 400-4/8T	1430 / 710		2.00 / 0.90	0.75 / 0.20	7000 / 3500	55 / 40	61 / 46	58
CHT CVT 400-4M	1380	4.40		0.75	7000	55	61	57
CHT CVT 400-6T	900	2.24	1.30	0.37	4500	44	50	56
CHT CVT 400-6M	910	1.80		0.37	4500	44	50	56
CHT CVT 450-4T	1430	5.96	3.44	1.50	10200	59	64	66
CHT CVT 450-4/8T	1420 / 700		3.50 / 1.50	1.50 / 0.37	10200 / 5100	59 / 43	64 / 49	66
CHT CVT 450-6T	900	2.24	1.30	0.37	6900	47	54	59
CHT CVT 450-6/12T	930 / 450		1.60 / 0.65	0.55 / 0.09	6900 / 3450	47 / 32	54 / 39	63
CHT CVT 450-6M	910	2.00		0.37	6900	47	54	59
CHT CVT 500-6T	945	4.88	2.82	1.10	12000	51	57	103
CHT CVT 500-6/12T	950 / 470		3.00 / 1.15	1.10 / 0.18	12000 / 6000	51 / 36	57 / 42	110
CHT CVT 500-8T	695	3.53	2.04	0.55	8900	44	50	103
CHT CVT 560-6T	955	9.30	5.30	2.20	17300	54	61	126
CHT CVT 560-6/12T	940 / 470		5.60 / 2.20	2.20 / 0.37	17300 / 8650	54 / 39	61 / 46	120
CHT CVT 560-8T	705	5.63	3.25	1.10	12900	46	53	110
CHT CVT 630-6T	960	16.50	9.46	4.00	24700	58	64	166
CHT CVT 630-6/12T	970 / 480		11.00 / 4.00	4.00 / 0.65	24700 / 12350	58 / 43	64 / 49	161
CHT CVT 630-8T	705	7.10	4.10	1.50	18400	50	57	148

(1) The sound level values are measurements of pressure in dB(A) at a distance of 6 m and at 2/3 of the maximum airflow (2/3 Qmax.)



Erp. BEP (best efficiency point) characteristics

MC	Measurement category	ηe[%]	Efficiency
EC	Efficiency category	N	Degree of efficiency
S	Static	[kW]	Electrical power
T	Total	[m³/h]	Airflow
VSD	Variable-speed drive	[mmH₂O]	Static or total pressure (According to EC)
SR	Specific relationship	[RPM]	Speed

Model	MC	EC	VSD	SR	ηe [%]	N	[kW]	[m3/h]	[mmH₂O]	[RPM]
200-4T	-	-	-	-	-	-	0.099	855	17.36	1462
200-4M	-	-	-	-	-	-	0.114	888	18.71	1467
225-4T	C	S	NO	1.00	41.2%	59.9	0.169	1205	21.26	1430
225-4M	C	S	NO	1.00	42.0%	60.1	0.189	1257	23.15	1442
225-6T	-	-	-	-	-	-	0.054	826	10.00	981
225-6M	-	-	-	-	-	-	0.068	875	11.21	986
250-4T	C	S	NO	1.00	45.0%	61.1	0.292	1788	26.99	1359
250-4M	C	S	NO	1.00	43.5%	59.3	0.315	1813	27.75	1377
250-6T	-	-	-	-	-	-	0.106	1262	13.44	959
250-6M	C	S	NO	1.00	40.6%	60.1	0.138	1344	15.26	971
315-4T	C	S	NO	1.00	50.4%	63.3	0.588	2652	41.02	1381
315-4/8T	C	S	NO	1.00	50.2%	62.4	0.690	2794	45.50	1454
315-4M	C	S	NO	1.00	48.1%	60.6	0.653	2705	42.67	1408
315-6T	C	S	NO	1.00	43.4%	61.4	0.192	1689	18.09	956
315-6M	C	S	NO	1.00	45.5%	62.9	0.219	1792	20.35	963
400-4T	C	S	NO	1.00	60.8%	72.4	0.788	4472	39.34	1411
400-4/8T	C	S	NO	1.00	52.3%	63.0	0.956	4536	40.48	1432
400-4M	C	S	NO	1.00	48.3%	59.1	0.942	4343	38.48	1419
400-6T	C	S	NO	1.00	48.9%	64.6	0.319	3148	18.20	926
400-6M	C	S	NO	1.00	51.3%	66.4	0.363	3338	20.46	933
450-4T	C	S	NO	1.01	60.6%	67.9	2.018	7176	62.55	1440
450-4/8T	C	S	NO	1.01	53.3%	60.1	2.254	7133	61.81	1431
450-6T	C	S	NO	1.00	54.1%	66.5	0.667	4779	27.75	959
450-6/12T	C	S	NO	1.00	49.0%	60.7	0.767	4844	28.51	948
450-6M	C	S	NO	1.00	47.6%	59.1	0.796	4854	28.63	925
500-6T	C	S	NO	1.00	62.9%	72.5	1.238	6832	41.88	923
500-6/12T	C	S	NO	1.00	61.7%	70.8	1.372	7023	44.25	957
500-8T	C	S	NO	1.00	47.1%	59.4	0.674	5027	23.21	695
560-6T	C	S	NO	1.01	59.4%	66.1	2.282	9457	52.64	956
560-6/12T	C	S	NO	1.01	53.4%	59.9	2.422	9313	51.05	942
560-8T	C	S	NO	1.00	53.0%	63.2	1.060	7052	29.27	713
630-6T	C	S	NO	1.01	63.0%	67.3	3.879	14310	62.66	968
630-6/12T	C	S	NO	1.01	58.3%	62.2	4.250	14377	63.25	973
630-8T	C	S	NO	1.00	58.0%	66.3	1.629	10429	33.28	706

Best efficiency point data of the motor-impeller unit

Acoustic features

The specified values are determined according to free field measurements of pressure and sound levels in dB(A) at a distance of 6 m.

Sound power Lw(A) spectrum in dB(A) via frequency band in Hz.

Values taken at the inlet with 2/3 of the maximum airflow (2/3Qmax).

Model	63	125	250	500	1000	2000	4000	8000
200	35	41	52	55	56	52	50	44
225-4	42	51	56	56	60	59	52	46
225-6	31	40	45	45	49	48	41	35
250-4	46	55	60	60	64	63	56	50
250-6	34	43	48	48	52	51	44	38
315-4	50	56	62	62	65	68	59	53
315-6	39	45	51	51	54	57	48	42
315-8	35	41	47	47	50	53	44	38
400-4	57	63	69	69	72	75	66	60
400-6	46	52	58	58	61	64	55	49
400-8	42	48	54	54	57	60	51	45
450-4	62	69	74	74	78	77	70	65
450-6	50	57	62	62	66	65	58	53
450-8	46	53	58	58	62	61	54	49
450-12	35	42	47	47	51	50	43	38
500-6	54	60	65	66	70	69	62	55
500-8	47	53	58	59	63	62	55	48
500-12	39	45	50	51	55	54	47	40
560-6	57	63	68	69	73	72	65	58
560-8	49	55	60	61	65	64	57	50
560-12	42	48	53	54	58	57	50	43
630-6	61	67	72	73	77	76	69	62
630-8	53	59	64	65	69	68	61	54
630-12	46	52	57	58	62	61	54	47

Values taken at outlet with 2/3 of the maximum airflow (2/3Qmax).

Model	63	125	250	500	1000	2000	4000	8000
200	39	44	58	60	61	61	56	51
225-4	41	50	60	64	67	64	57	51
225-6	30	39	49	53	56	53	46	40
250-4	44	53	63	67	70	67	60	54
250-6	34	43	53	57	60	57	50	44
315-4	49	61	69	71	72	72	64	56
315-6	38	50	58	60	61	61	53	45
315-8	34	46	54	56	57	57	49	41
400-4	56	68	76	78	79	79	71	63
400-6	45	57	65	67	68	68	60	52
400-8	41	53	61	63	64	64	56	48
450-4	60	72	80	82	83	80	73	65
450-6	50	62	70	72	73	70	63	55
450-8	45	57	65	67	68	65	58	50
450-12	35	47	55	57	58	55	48	40
500-6	50	64	72	76	75	72	66	60
500-8	43	57	65	69	68	65	59	53
500-12	35	49	57	61	60	57	51	45
560-6	54	68	76	80	79	76	70	64
560-8	46	60	68	72	71	68	62	56
560-12	39	53	61	65	64	61	55	49
630-6	57	71	79	83	72	79	73	67
630-8	50	64	72	76	72	72	66	60
630-12	42	56	64	68	67	64	58	52

To obtain the Lwa sound power spectra in dB(A) at the inlet with the maximum airflow (Qmax), add the values in the following tables to the LpA sound pressure level given on the characteristic curves:

Frequency band in Hz							
63	125	250	500	1000	2000	4000	8000
2	9	15	15	18	18	11	5

Dimensions in mm

CHT

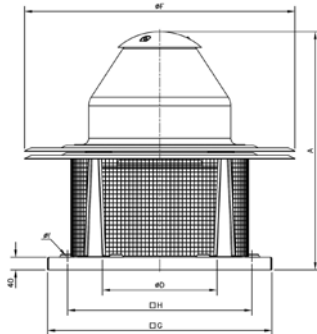

Model	A	øD*	øF	G	H	øl
CHT-200	552	250	570	450	360	12
CHT-225	570	250	570	450	360	12
CHT-250	632	355	726	560	450	12
CHT-315	682	355	726	560	450	12
CHT-400	755	500	856	710	590	12
CHT-450	770	500	856	710	590	12
CHT-500	846	630	1075	900	750	14
CHT-560	1035	710	1300	1100	900	14
CHT-630	1098	710	1300	1100	900	14

(*) Recommended nominal diameter for duct.

CVT

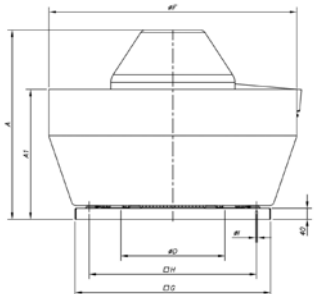

Model	A	A1	øD*	øF	G	H	øl
CVT-200	500	308	250	530	450	360	12
CVT-225	517	308	250	530	450	360	12
CVT-250	580	380	355	705	560	450	12
CVT-315	630	380	355	705	560	450	12
CVT-400	690	475	500	900	710	590	12
CVT-450	705	475	500	900	710	590	12
CVT-500	775	545	630	1100	900	750	14
CVT-560	956	676	710	1295	1100	900	14
CVT-630	1017	676	710	1295	1100	900	14

(*) Recommended nominal diameter for duct.

Accessories

See accessories section



Characteristic Curves

Q = Airflow in m³/h, m³/s and cfm.
Pe = Static pressure in mmH₂O, Pa and inwg.
The Lp (dB(A)) sound levels given on the curves are free field pressure measurements at 6 metres at the inlet.

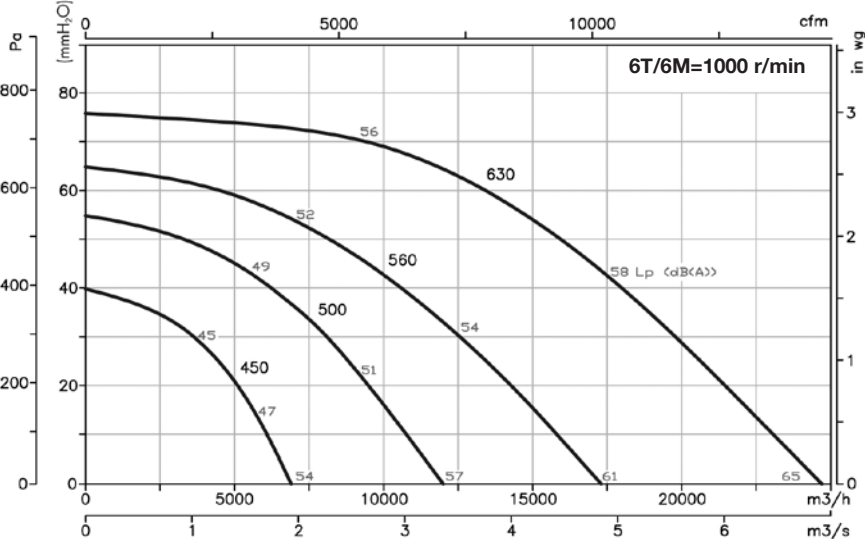
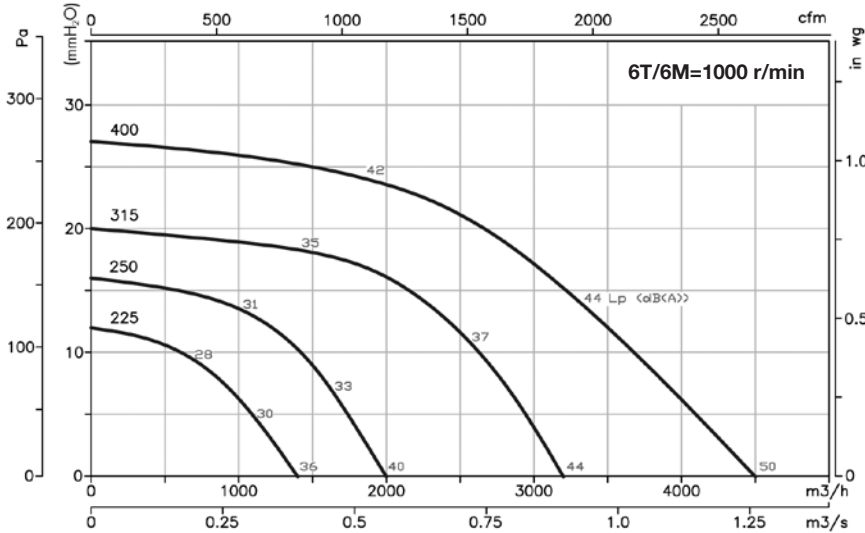
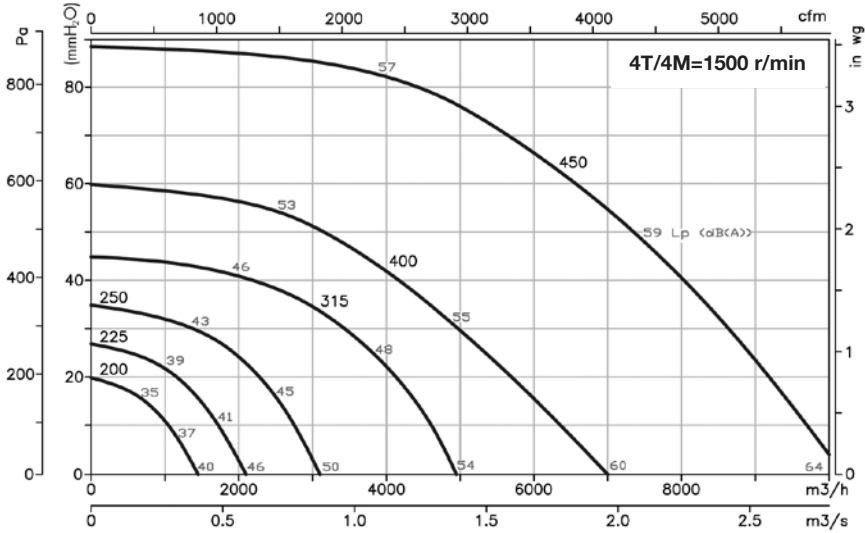

Characteristic Curves

Q = Airflow in m³/h, m³/s and cfm.

Pe= Static pressure in mmH₂O, Pa and inwg.

The Lp (dB(A)) sound levels given on the curves are free field pressure measurements at 6 metres at the inlet.

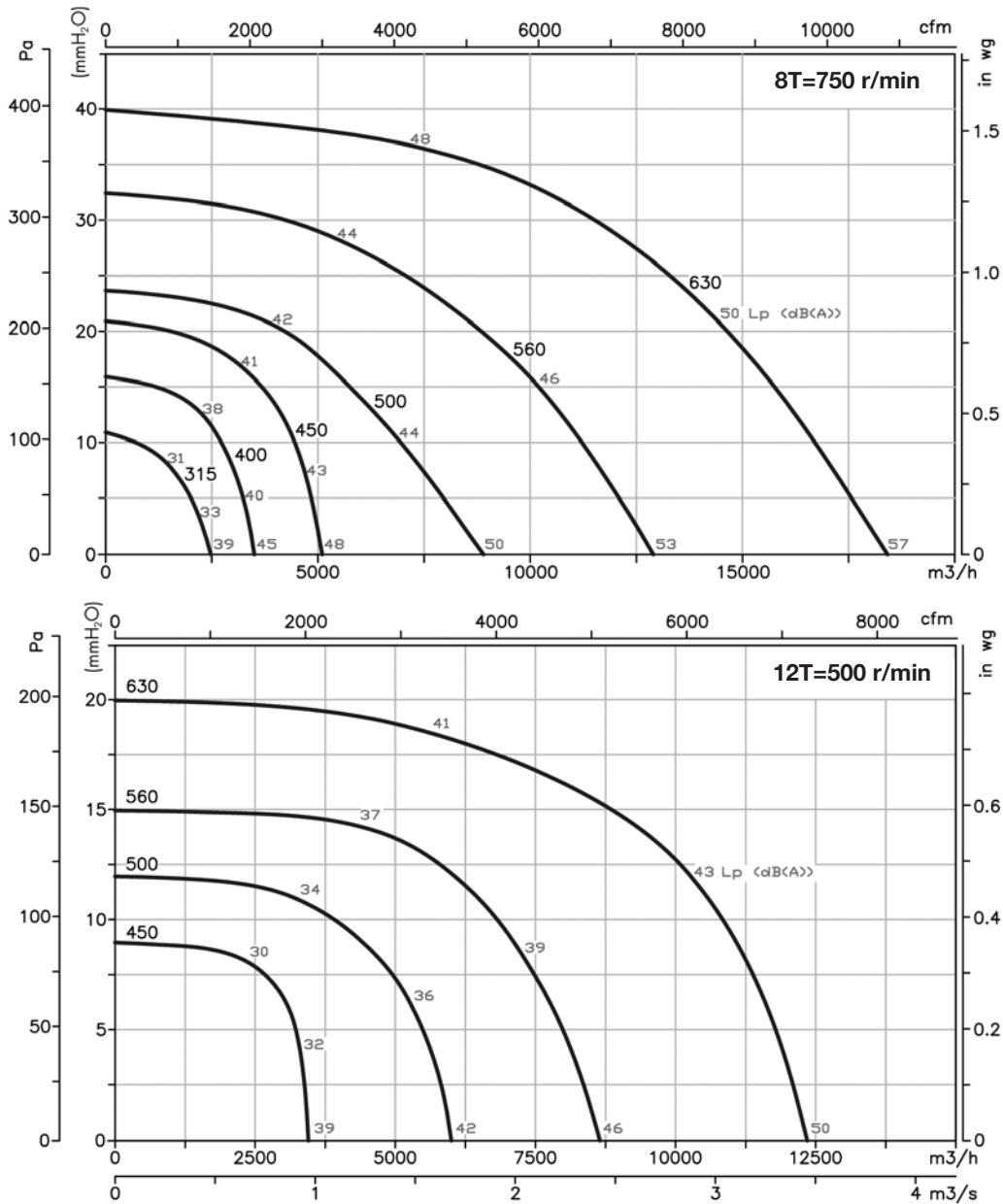

Variation of sound pressure depending on distance

The sound level may vary depending on the roof structure.

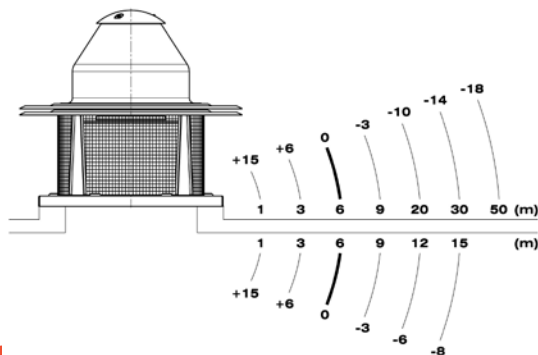

Example of use

Fans suitable for use in industrial kitchens.

For the correct application of the standard:

- Technical Building Code. Basic SI Document for fire safety. Basic HS Document for health and safety.

