



SV SV/PLUS SV/ECO

SV: Low noise in-line duct fans mounted in acoustic casing

SV/PLUS: Low noise in-line duct fans mounted in acoustic casing with 50mm insulation

SV/ECO: Low noise in-line duct fans mounted in acoustic casing with 50 mm insulation, fitted with EC motors



SV



SV/PLUS



SV/ECO

Fan:

- Acoustic casing covered with deadening material
- SV: Impeller with backward-curved blades, except models 125-150-200, with multi-blade impeller
- SV/PLUS: Multi-blade impeller for all models
- SV/ECO: Backward-curved impeller for all models
- Standard flanged inlet and outlet to aid installation on duct
- They are supplied with 4 base stands to aid installation
- Linear air circulation
- T-models are fitted with 1-5 minute adjustable timer.

Motor:

- Class F motors with external rotor incorporated thermal protector, ball bearings and IP54 protection
- Single-phase 230V.-50/60Hz. adjustable
- Max. air temperature to transport: + 50°C.
- SV/ECO: Highly-efficient brushless-EC motor, electronically controlled by means of a potentiometer of 10KΩ MTP010, or an external signal of 0-10VDC

Finish:

- Anticorrosive finish in polyester resin, polymerised at 190°C, after alkaline degreasing and phosphate-free pre-treatment.

Order code

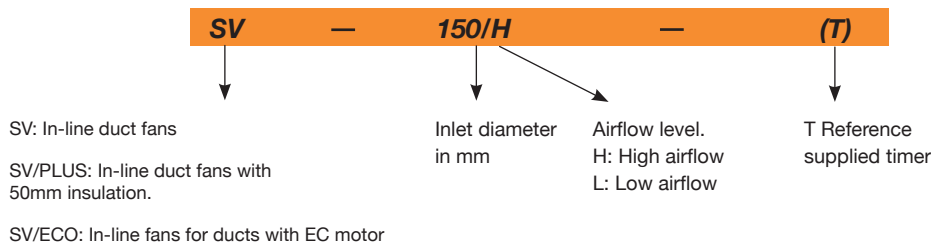

Technical characteristics

Model	Speed (r/min)	Maximum admissible current 230V (A)	Installed power (kW)	Maximum airflow (m³/h)	Irradiated sound level dB(A)	Approx. weight (Kg)
SV-125/H	2720	0.65	0.11	400	32	5.2
SV-125/H-T	2720	0.65	0.11	400	32	5.2
SV-150/H	2580	1.00	0.16	560	40	6.8
SV-150/H-T	2580	1.00	0.16	560	40	6.8
SV-200/H	1400	0.75	0.12	880	44	8.0
SV-200/H-T	1400	0.75	0.12	880	44	8.0
SV-200/L	1450	0.70	0.09	760	42	8.0
SV-250/H	2500	0.85	0.18	1300	48	10.8
SV-250/L	2680	0.75	0.16	1000	46	10.8
SV-315/H	1400	0.65	0.12	2100	50	21.0
SV-350/H	1400	0.95	0.14	2850	51	28.5
SV-400/H	1350	1.80	0.30	3500	53	38.0

Technical characteristics

Model	Speed (r/min)	Maximum admissible current (A)		Installed power (kW)	Maximum airflow (m³/h)	Irradiated sound level* dB(A)	Approx. weight (Kg)
		230V					
SV/PLUS-125/H	2335	0.33	0.08	0.08	260	30	12.0
SV/PLUS-160/H	2480	0.59	0.14	0.14	465	36	13.0
SV/PLUS-200/H	1550	0.72	0.17	0.17	700	37	17.0
SV/PLUS-250/H	2082	1.15	0.27	0.27	1050	38	18.0

* Sound pressure level dB(A) are measurements at a distance of 1.5 meters

Model	Speed (r/min)	Maximum admissible current (A)		Installed power (kW)	Maximum airflow (m³/h)	Sound pressure level to 50% of max. speed* dB(A)	Approx. weight (Kg)
		230V					
SV/ECO-125/H	4480	0.46	0.055	0.055	367	29	12.0
SV/ECO-160/H	3490	0.99	0.114	0.114	565	28	19.0
SV/ECO-200/H	3380	1.48	0.192	0.192	914	39	24.0
SV/ECO-250/H	3220	1.69	0.213	0.213	1107	32	24.0
SV/ECO-315/H	3580	2.8	0.448	0.448	1638	49	31.0

* Sound pressure level dB(A) are measurements at a distance of 1.5 meters



Erp. BEP (best efficiency point) characteristics

MC	Measurement category	ηe[%]	Efficiency
EC	Efficiency category	N	Efficiency grade
S	Static	[kW]	Input power
T	Total	[m³/h]	Airflow
VSD	Variable-speed drive	[mmH₂O]	Static or total pressure (According to EC)
SR	Specific ratio	[RPM]	Speed

Model	MC	EC	VSD	SR	ηe[%]	N	(kW)	(m³/h)	(mmH₂O)	(RPM)
SV-125/H	-	-	-	-	-	-	0.118	207	29.9	2768
SV-125/H-T	-	-	-	-	-	-	0.118	207	29.9	2768
SV-150/H	-	-	-	-	-	-	0.125	296	40.3	2761
SV-150/H-T	-	-	-	-	-	-	0.125	296	40.3	2761
SV-200/H	-	-	-	-	-	-	0.102	434	17.1	1438
SV-200/H-T	-	-	-	-	-	-	0.102	434	17.1	1438
SV-200/L	-	-	-	-	-	-	0.113	396	16.0	1463
SV-250/L	-	-	-	-	-	-	0.119	381	38.7	2767
SV-315/H	-	-	-	-	-	-	0.125	991	18.0	1412
SV-350/H	A	S	NO	1.00	43.4%	60.4	0.240	1537	24.9	1401
SV-400/H	A	S	NO	1.00	45.6%	60.6	0.377	1701	37.1	1364
SV/PLUS-125/H	-	-	-	-	-	-	0.064	116	22.96	2368
SV/PLUS-160/H	-	-	-	-	-	-	0.105	231	33.96	2485
SV/PLUS-200/H	-	-	-	-	-	-	0.123	295	28.26	1619
SV/PLUS-250/H	A	S	NO	1.00	27.1%	38.2	0.176	645	27.03	2141
SV/ECO-125/H	-	-	-	-	-	-	0.053	200	20.30	4480
SV/ECO-160/H	-	-	-	-	-	-	0.110	307	48.49	3490
SV/ECO-200/H	A	S	INCLUDED	1.00	47.7%	66.0	0.183	505	55.62	3380
SV/ECO-250/H	A	S	INCLUDED	1.00	47.5%	65.1	0.209	597	53.77	3220
SV/ECO-315/H	A	S	INCLUDED	1.00	48.8%	63.1	0.433	902	77.23	3580

Acoustic features

The specified values are determined according to free field measurements of sound levels in dB(A) at an equivalent distance of twice the fan's span plus the impeller's diameter, with a minimum of 1.5 m.

Sound power Lw(A) spectrum in dB(A) via frequency band in Hz.

Model	63	125	250	500	1000	2000	4000	8000	Model	63	125	250	500	1000	2000	4000	8000
125/H	22	32	36	34	33	34	30	24	SV/PLUS-125/H	35	46	52	57	64	62	55	48
150/H	31	41	42	44	45	46	42	36	SV/PLUS-160/H	43	54	61	66	72	71	67	63
200/H	31	42	47	51	50	47	43	33	SV/PLUS-200/H	43	55	58	62	69	68	66	61
200/L	29	39	46	47	47	46	45	37	SV/PLUS-250/H	49	58	64	70	72	80	70	65
250/H	32	42	47	54	55	53	50	41	SV/ECO-125/H	31	41	54	56	45	45	40	44
250/L	33	43	47	53	51	50	48	41	SV/ECO-160/H	39	49	63	60	49	51	48	46
315/H	34	44	49	56	57	55	52	43	SV/ECO-200/H	42	52	66	60	56	54	51	52
350/H	38	48	52	59	60	58	56	47	SV/ECO-250/H	48	57	70	64	66	59	53	52
400/H	40	50	54	61	62	60	58	49	SV/ECO-315/H	50	59	73	67	68	65	58	55

Dimensions in mm

SV

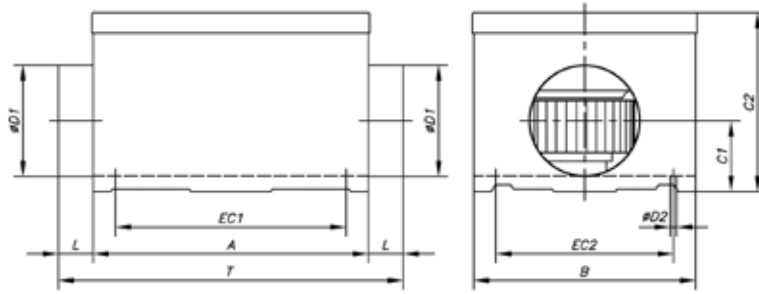

Model	A	B	C1	C2	øD1	L	øD2	EC1	EC2	T
SV-125/H	310	250	80	201	125	36.5	7	260	200	383
SV-150/H	370	290	92	222	150	34.5	7	320	240	439
SV-200/H	430	340	117	246	200	34.5	7	380	290	499
SV-200/L	430	340	117	246	200	34.5	7	380	290	499
SV-250/H	480	395	140	296	250	51.5	7	430	345	583
SV-250/L	480	395	140	296	250	51.5	7	430	345	583
SV-315/H	565	490	173.5	370	315	55	8.5	515	440	675
SV-350/H	650	550	200	410	355	57	8.5	600	500	764
SV-400/H	725	610	200	454	400	70	8.5	675	560	865

SV/PLUS

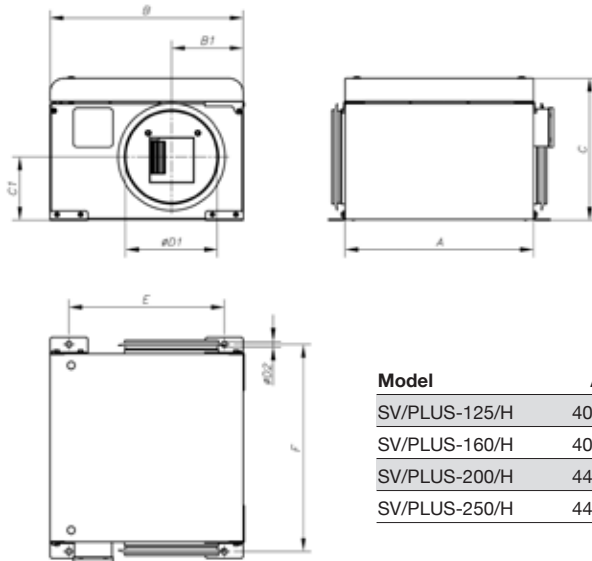

Model	A	B	B1	C	C1	øD1	øD2	E	F
SV/PLUS-125/H	400	410	277	300	171.5	125	12.5	330	440
SV/PLUS-160/H	400	410	148.5	300	142.5	160	12.5	330	440
SV/PLUS-200/H	444	444	222	420	251.5	200	12.5	364	484
SV/PLUS-250/H	444	444	222	420	221.5	250	12.5	364	484

SV/ECO

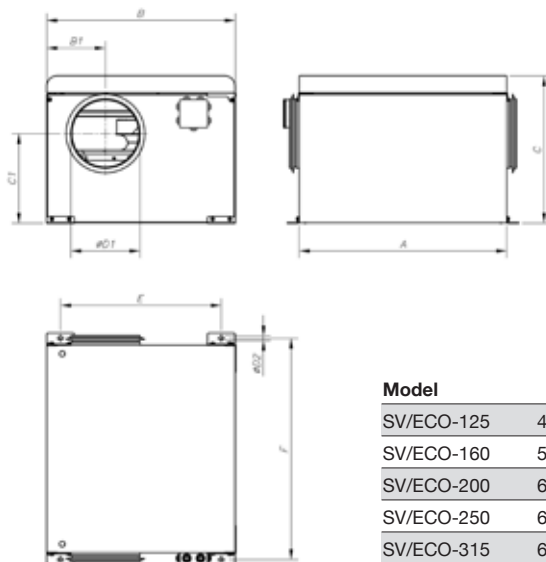

Model	A	B	B1	C	C1	øD1	øD2	E	F
SV/ECO-125	400	410	205	325	165.5	125	12.5	330	440
SV/ECO-160	550	485	149	340	194.5	160	12.5	405	590
SV/ECO-200	600	545	170	425	259.5	200	12.5	465	640
SV/ECO-250	600	545	194	425	234.5	250	12.5	465	640
SV/ECO-315	675	595	227.5	475	251.5	315	12.5	515	715

Characteristic curves

Q = Airflow in m³/h, m³/s and cfm.

Pe = Static pressure in mm.w.c., Pa and inwg.

SV

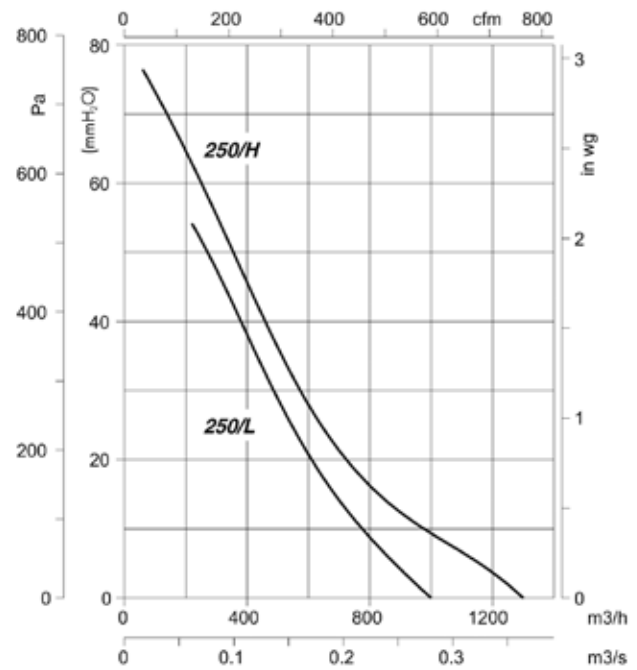
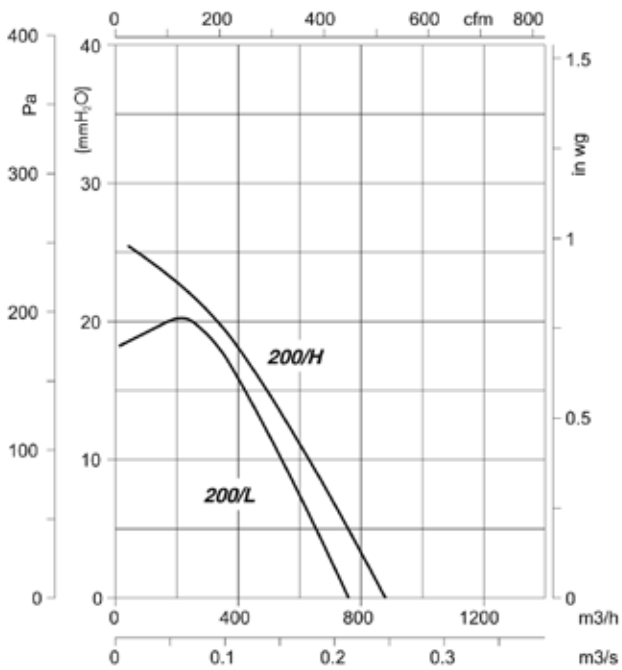
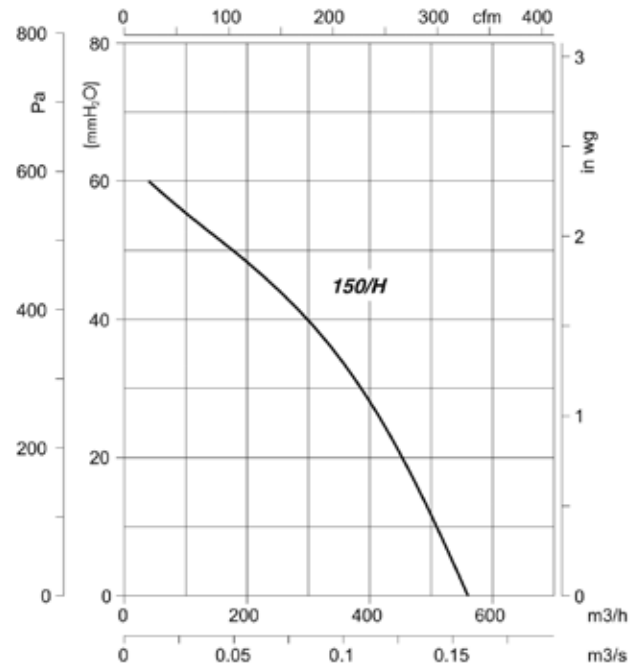
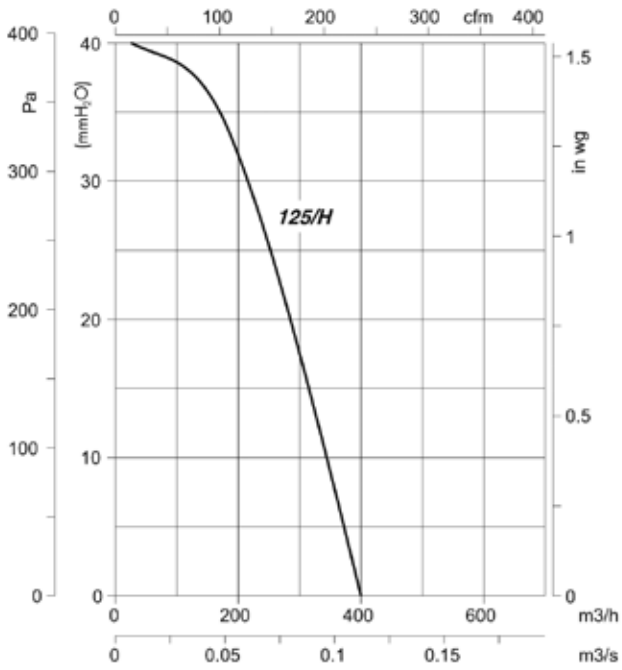

Characteristic curves

Q = Airflow in m³/h, m³/s and cfm.

Pe= Static pressure in mm.w.c., Pa and inwg.

SV

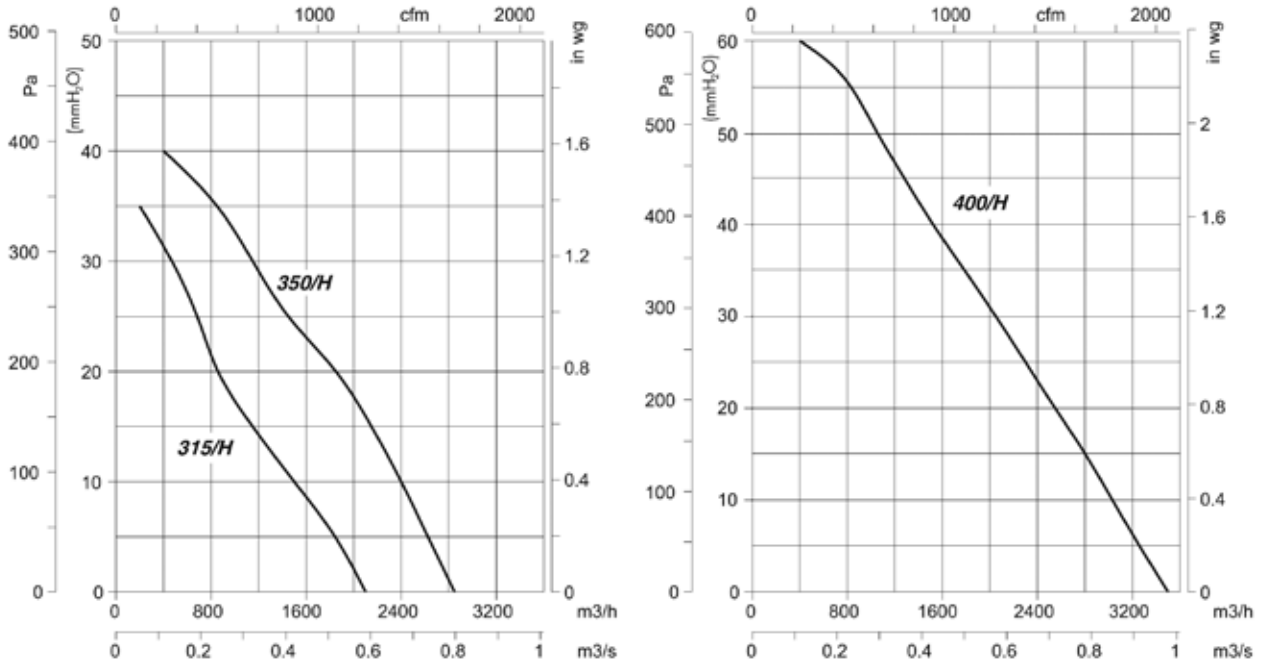

SV/PLUS

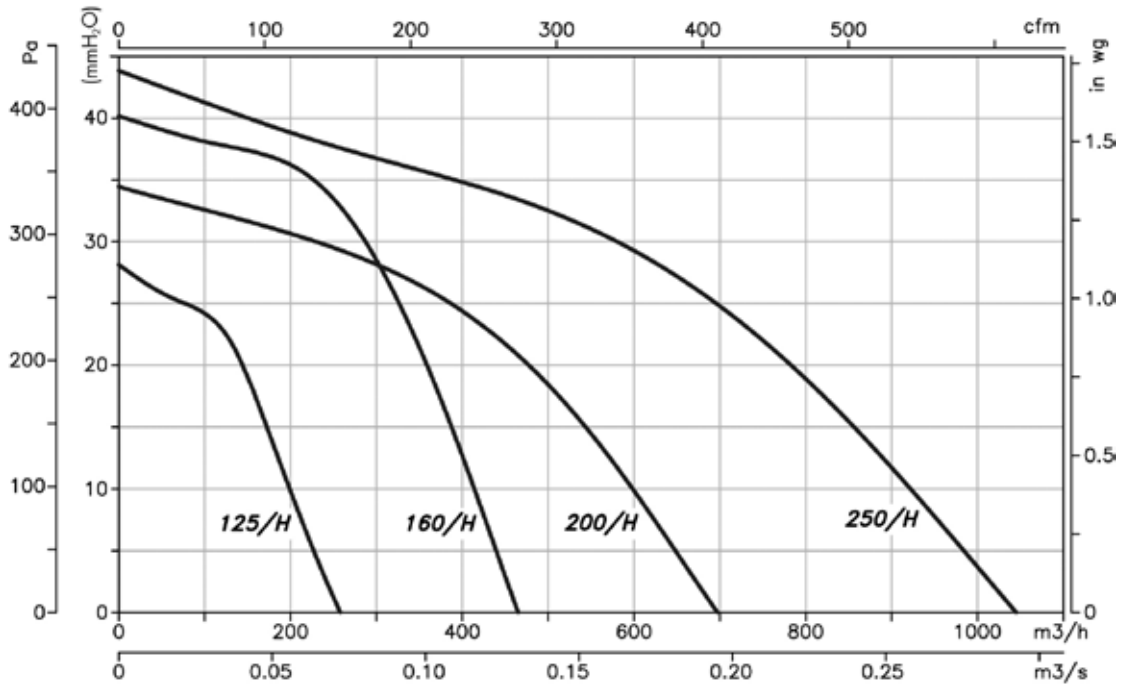

Characteristic curves

Q = Airflow in m³/h, m³/s and cfm.

Pe = Static pressure in mm.w.c., Pa and inwg.

SV/ECO

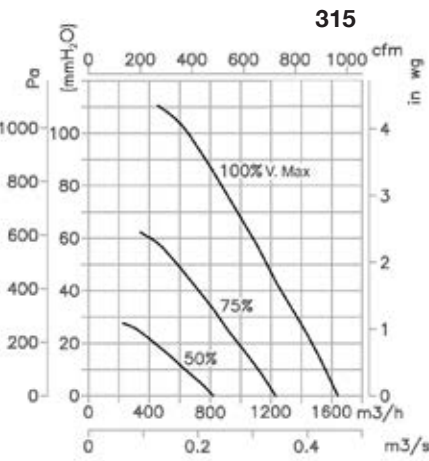
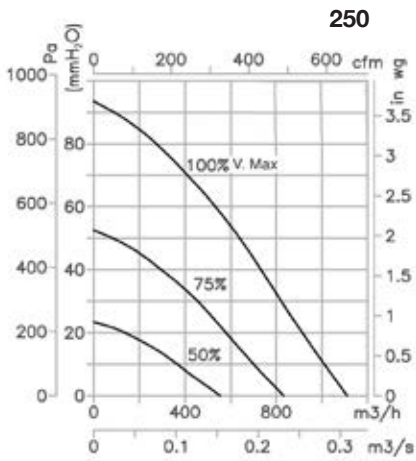
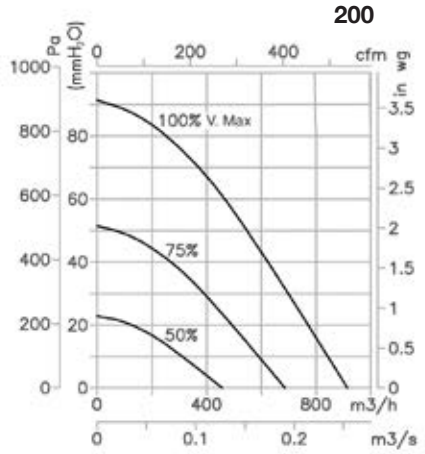
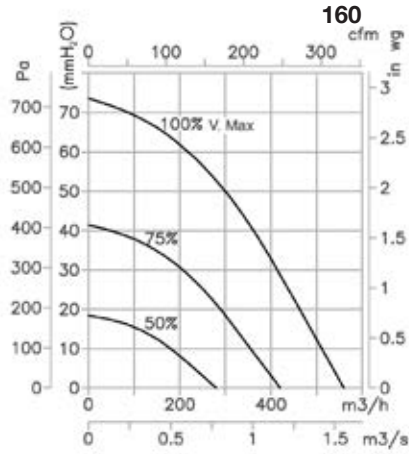
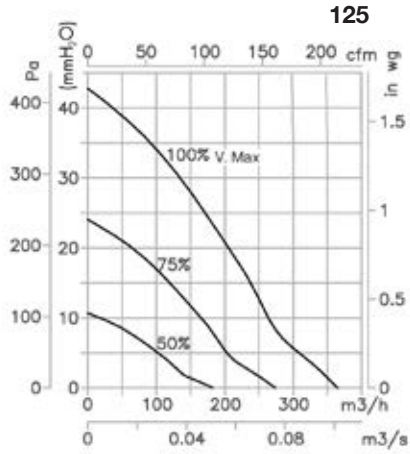

Accessories

See accessories section.

